



THOMSON

SERIES TS 880 • 800 - 4000 AMP AUTOMATIC TRANSFER SWITCHES

MISSION CRITICAL, INDUSTRIAL

REGAL[®]

THOMSON POWER SYSTEMS TS 880 AUTOMATIC TRANSFER SWITCHES OFFER THE FOLLOWING:

ENCLOSED CONTACT POWER SWITCHING UNITS

- Fully enclosed silver alloy contacts provide high withstand rating & 100% continuous current rating
- 3 and 30-Cycle short circuit current withstand tested
- Completely separate utility and generator side power switching units
- Not damaged if manually switched while in service
- Safe manual operation permits easy operation

SUPERIOR SERVICEABILITY

- All mechanical and control devices are visible and readily accessible

CONTROL FEATURES

- TSC 7320 Microprocessor Based Controller with comprehensive features
- Isolation plug permits disconnecting control circuits from all power sources

PRODUCT DATA

- Models available from 800 - 4000A continuous
- Available 3 or 4 Pole
- All models 50/60Hz rated
- Voltage range 208 - 600V
- 3 Phase, 3 or 4 wire systems

QUALITY ASSURANCE

- ISO 9001 Registered

SEISMIC CERTIFICATION

TS 880 is certified for installation and operation per the following requirements:

- IBC 2012 – Section 13, Occupancy Category IV
- ASCE7 - 05 Region 3 (minimum SS=200%)
- OSHPD Certified

SAFETY STANDARDS

- UL 1008
- CSA C22.2 No. 178 Automatic Transfer Switches

WARRANTY

- 2 year limited warranty included

Thomson Power Systems TS 880 Automatic Transfer Switches employ two mechanically interlocked power switching units with a microprocessor based controller to automatically start a generator and transfer system load to a generator supply in the event of a utility supply failure. System load is then automatically retransferred back to the utility supply following restoration of the utility power source to within normal operating limits. All load transfer sequences are open transition (i.e. break-before-make) with adjustable neutral position delay unless the closed transition option is supplied with the transfer switch. The optional 30-Cycle rated ATS utilizes insulated case switch power switching devices in ratings 800A through 4000A, up to 600VAC.

The standard TS 880 Automatic Transfer Switch is rated for 100% system load. The TS 880 design allows for optional use of integral over current trip elements within the power switching units. All TS 880 Automatic Transfer Switches use a TSC 7320 microprocessor based controller which provides all necessary control functions for fully automatic operation. The controller is equipped with 2.3" back-lit LCD display which provides operating status and controls. All parameters and configurations are entered without opening the front door.

TS 880 Automatic Transfer Switches are specifically designed and certified to CSA C22.2 No. 178 & UL 1008 Standards. All TS 880 application and options are available for the 3 and 30-Cycle designs including:

- Closed Transition
- Bypass Isolation Automatic Transfer Switch
- Service Entrance
- CSA Type B with integrated over current protection and ground fault protection

The TS 880 30-Cycle shares the same design as Thomson Power Systems UL 1558 LV Power Circuit Breaker Switchgear; therefore it can be seamlessly integrated into a Parallel Generation Switchgear package.

SERVICE ENTRANCE ATS (For U.S. Market Only)

Thomson Power Systems TS 880 Service Entrance (SE) Automatic Transfer Switches incorporate an isolating mechanism and over current protection on the utility supply, thereby removing the need to have a separate, upstream circuit breaker/ disconnect switch. This unique service entrance rated automatic transfer switch design is incorporated into a standard sized automatic transfer switch enclosure.

The Service Entrance Rated ATS feature is a standard option that can be applied to any TS 880 model of Thomson Power Systems Transfer Switch.

Standard features of the Service Entrance Rated Automatic Transfer Switch include a NEMA 1 rated enclosure, padlockable Service Disconnect control switch and status indications.

TS 880 SE service disconnect operation is simple and ensures a high level of safety for system maintenance personnel. Normal operation and performance of the Automatic Transfer Switch is unaffected by the Service Entrance ATS feature.

TS 880 SE Automatic Transfer Switches are specifically designed and certified to the UL 1008 Standard as well as complying with NEC and NFPA requirements. TS 880 SE Automatic Transfer Switches are for use in emergency power system applications such as commercial, industrial or government institutions that require automatic standby power.

All TS 880 SE Automatic Transfer Switch models have been 3 or 30-Cycle withstand current tested in accordance with UL 1008 and CSA 178, which allow high current rating and use of nonseries rated upstream protective devices. The TS 880 SE Automatic Transfer Switch is rated for the system load and requires upstream over current protection on the generator supply.

The TS 880 SE Automatic Transfer Switches use a type TSC 7320 microprocessor based controller.

TYPICAL SINGLE LINE DIAGRAM

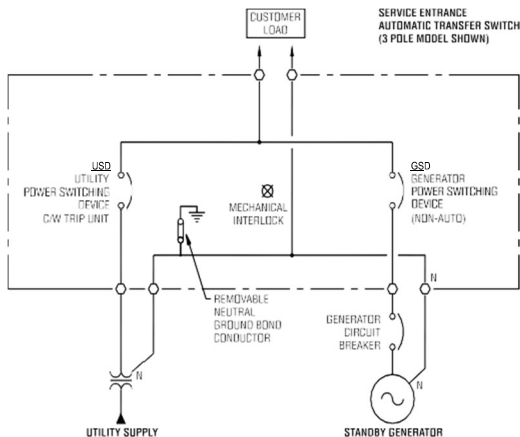

OPERATION MODE

Service Entrance Automatic Transfer Switch	Utility Power Switching Device	Generator Power Switching Device	ATS Load
Operation Mode	Position	Position	
Normal Conditions (Utility Power Supplying Load)	Closed	Open	Energized
Utility Power Failure (Generator Supplying Load)	Open	Closed	Energized
Service	Open	Open	De-Energized
Disconnect Mode	(Mechanically & electrically interlocked)	(Mechanically & electrically interlocked)	

CLOSED TRANSITIONS ATS (MOMENTARY)

Thomson Power Systems TS 880 Closed Transition Automatic Transfer Switches (CTTS) employ two electrically interlocked insulated case power switching units and a TSC 7320 microprocessor based controller to automatically allow a closed transition load transfer when both utility and generator sources are available. All closed transition transfer sequences ensure both sources of power are in synchronism prior to transfer and load is transferred without power interruption. Automatic control & protection circuits ensure the generator and utility supplies are only in parallel for a maximum of 100 ms to permit an uninterrupted load transfer.

In the event of a utility supply failure, the TS 880 CTTS will automatically revert to an open transition load transfer sequence to transfer system load automatically to the generator supply. System load is then automatically retransferred back to the utility supply utilizing a closed transition transfer sequence following restoration of the utility power source to within normal operating limits. All closed transition transfer sequences will be inhibited when only one source of power is available. The closed transition feature is a standard option that can be applied to TS 880 models of Thomson Power Systems Transfer Switches 800A and above.

TS 880 CTTS are specifically designed and certified to UL 1008 Standards. For use in emergency power systems applications such as commercial, industrial, or government institutions that require automatic standby power and minimal power interruptions to the load.

All TS 880 CTTS models have been 3 or 30-Cycle withstand current tested in accordance with UL 1008.

The standard TS 880 Automatic Transfer Switch is rated for 100% system load and requires upstream over current protection. The TS 880 CTTS designs allows optional use of integral over current trip elements within the power switching units, thus eliminating the need for external, upstream protective devices.

The TS 880 CTTS use the TSC 7320 controller, with built in sync check relay which contains adjustable voltage/slip frequency threshold limits. The paralleling time is less than 100 ms. A timer monitors the closed-transition period, and will isolate, should the closed-transition time exceed the setting of the timer. If the device fails to open within 100 ms an additional Extended Paralleling Protection is provided to ensure isolation by opening the other source within 500 ms.

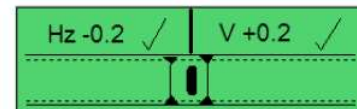
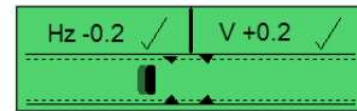
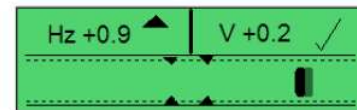

BYPASS ISOLATION ATS

Thomson Power Systems TS 880 Bypass/Isolation Automatic Transfer Switches employ an interlock power switching mechanism that provides an easy and safe procedure for system maintenance personnel to manually isolate and bypass an Automatic Transfer Switch. The Bypass/Isolation switch is manually operated, and allows either generator or utility source to be bypassed to maintain power to the load while the Automatic Transfer Switch is tested for maintenance procedures as required. The Bypass/Isolation procedure allows a fast, simple and reliable method of isolating and bypassing the Automatic Transfer Switch through a break-before-make bypass design. The mechanical interlocking mechanism ensures that the utility and generator sources cannot be paralleled under any circumstance and the transfer switch may be bypassed to either source.

Note: Automatic Transfer Switch units rated 800A - 4000A utilizing insulated case power switching units with a closed transition option may be operated in a make-before-break sequence at the operators' direction.

The TS 880 Bypass/Isolation Automatic Transfer Switch is supplied as a single complete assembly with all power conductors provided between the bypass mechanism and the transfer switch. Provisions for all external power cabling for the utility, generator and load conductors are provided for in the bypass/isolation compartment of the switch. The Bypass/Isolation Switch and Transfer Switch are mounted in separate barriered compartments.

Transfer switches rated 800A - 4000A using insulated case power switching devices, the bypass/isolation mechanism consists of two mechanically interlocked power switch devices and drawout transfer power switching devices with key interlock mechanism. Utilizing independent switching units provides a high degree of reliability and redundancy not available in other switches.

The bypass isolation mechanism consists of two mechanically interlocked power switching devices and drawout transfer power switching devices with key interlock mechanism. Utilizing independent switching units provides a high degree of reliability and redundancy not available in other switches.

TS 880 Bypass/Isolation Automatic Transfer Switches are specifically designed and certified to UL 1008 and CSA 22.2 No. 178 Safety Standards.

The standard TS 880 Bypass/Isolation Automatic Transfer Switch is rated for 100% system load and requires upstream over current protection.

TYPICAL SINGLE LINE DIAGRAM

800A - 4000A Insulated Case
Bypass/Isolation Automatic Transfer Switch

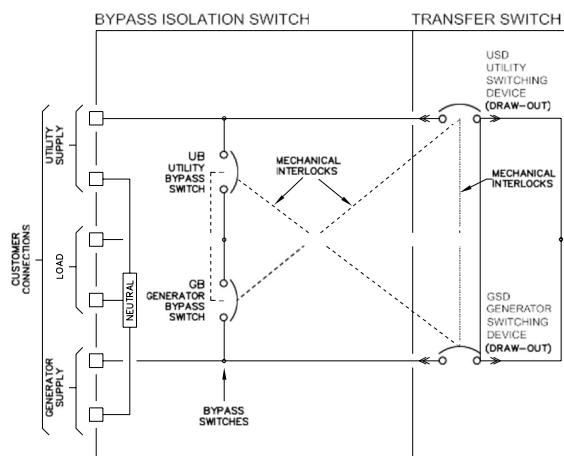

WITHSTAND CURRENT RATINGS (3 CYCLE MODELS)

MODEL	TYPE	MAX VOLTAGE	RATED CURRENT (AMPS)	WITHSTAND CURRENT RATING AMPS (RMS)		
				@240V	@480V	@600V
TS 88xA-0800	MASTERPACT	600	800A	100,000	100,000	85,000
TS 88xA-1200	MASTERPACT	600	1200A	100,000	100,000	85,000
TS 88xA-1600	MASTERPACT	600	1600A	100,000	100,000	85,000
TS 88xA-2000	MASTERPACT	600	2000A	100,000	100,000	85,000
TS 88xA-2500	MASTERPACT	600	2500A	100,000	100,000	85,000
TS 88xA-3000	MASTERPACT	600	3000A	100,000	100,000	85,000
TS 88xA-4000	MASTERPACT	600	4000A	100,000	100,000	85,000
TS 88xA-1600	EMAX2	600	1600A	85,000	85,000	85,000
TS 88xA-2000	EMAX2	600	2000A	85,000	85,000	85,000
TS 88xA-2500	EMAX2	600	2500A	100,000	100,000	100,000
TS 88xA-3200	EMAX2	600	3200A	100,000	100,000	100,000
TS 88xA-4000	EMAX2	600	4000A	100,000	100,000	100,000

For higher interrupt ratings contact — consult Thomson Power Systems

WITHSTAND CURRENT RATINGS (30-CYCLE MODELS)

MODEL	TYPE	MAX VOLTAGE	RATED CURRENT (AMPS)	WITHSTAND CURRENT RATING AMPS (RMS)			
				@240V 3 CYCLE	@480V 3 CYCLE	@600V 3 CYCLE	UP TO 600V 30-CYCLE
TS 88xA-0800	MASTERPACT	600	800A	65,000	65,000	65,000	65,000
TS 88xA-1200	MASTERPACT	600	1200A	65,000	65,000	65,000	65,000
TS 88xA-1600	MASTERPACT	600	1600A	65,000	65,000	65,000	65,000
TS 88xA-2000	MASTERPACT	600	2000A	65,000	65,000	65,000	65,000
TS 88xA-2500	MASTERPACT	600	2500A	65,000	65,000	65,000	65,000
TS 88xA-3200	MASTERPACT	600	3000A	65,000	65,000	65,000	65,000
TS 88xA-4000	MASTERPACT	600	4000A	65,000	65,000	65,000	65,000
TS 88xA-1600	EMAX2	600	1600A	85,000	85,000	85,000	85,000
TS 88xA-2000	EMAX2	600	2000A	85,000	85,000	85,000	85,000
TS 88xA-2500	EMAX2	600	2500A	100,000	100,000	100,000	100,000
TS 88xA-3200	EMAX2	600	3200A	100,000	100,000	100,000	100,000
TS 88xA-4000	EMAX2	600	4000A	100,000	100,000	100,000	100,000

For higher interrupt ratings contact — consult Thomson Power Systems

ENCLOSURE DIMENSIONS/CABLE TERMINATIONS (ATS only)

AMPERAGE	DIMENSIONS ¹				SHIPPING WEIGHT lbs (kg)	TERMINAL RATING ²	
	HEIGHT INCHES (mm)	WIDTH INCHES (mm)	DEPTH ³ INCHES (mm)	DEPTH ³ (DRAWOUT OPTION)		QTY (PER PHASE)	RANGE
800A	91.5" (2324)	36" (914)	42" (1067)	48"	1500 lbs (680)	3	#2 - 600 mcm
1200A	91.5" (2324)	36" (914)	42" (1067)	48"	1500 lbs (680)	4	#2 - 600 mcm
1600A	91.5" (2324)	36" (914)	42" (1067)	48"	1500 lbs (680)	5	#2 - 600 mcm
2000A	91.5" (2324)	36" (914)	42" (1067)	48"	1500 lbs (680)	6	#2 - 600 mcm
2500A	91.5" (2324)	36" (914)	60" (1524)	60"	1800 lbs (817)	8	#2 - 600 mcm
3000 / 3200A	91.5" (2324)	36" (914)	60" (1524)	60"	2000 lbs (907)	9	#2 - 600 mcm
4000A	91.5" (2324)	48" (1219)	72" (1829)	72"	3000 lbs (1361)	12	#2 - 600 mcm

Optional NEMA 1,12, 2, 3R & 3RX class enclosures available — consult Thomson Power Systems.

1 Enclosure dimensions are for reference. (Not intended for construction purposes).

2 All cable connections suitable for copper or aluminum.

3 Enclosure depth shown has cable entry/exit location restrictions. Contact factory for further detailed information.

* Enclosures painted ASA #61 Gray.

ENCLOSURE DIMENSIONS/CABLE TERMINATIONS (ATS with Bypass Switch)

AMPERAGE	NEMA 1 DIMENSIONS ¹						SHIPPING WEIGHT lbs (kg)		TERMINAL RATING ²	
	HEIGHT INCHES (mm)		WIDTH INCHES (mm)		DEPTH ³ INCHES (mm)				QTY (PER PHASE)	RANGE
	3 POLE	4 POLE	3 POLE	4 POLE	3 POLE	4 POLE	3 POLE	4 POLE		
800A	92" (2337)	92" (2337)	72" (1829)	72" (1829)	66" (1829)	66" (1829)	3200 lbs (1451)	3800 lbs (1724)	3	#2 - 600 mcm
1200A	92" (2337)	92" (2337)	72" (1829)	72" (1829)	66" (1829)	66" (1829)	3200 lbs (1451)	3800 lbs (1724)	4	#2 - 600 mcm
1600A	92" (2337)	92" (2337)	72" (1829)	72" (1829)	66" (1829)	66" (1829)	3200 lbs (1451)	3800 lbs (1724)	5	#2 - 600 mcm
2000A	92" (2337)	92" (2337)	72" (1829)	72" (1829)	66" (1829)	66" (1829)	3200 lbs (1451)	3800 lbs (1724)	6	#2 - 600 mcm
2500A	92" (2337)	92" (2337)	72" (1829)	72" (1829)	66" (1829)	66" (1829)	3600 lbs (1633)	4250 lbs (1928)	8	#2 - 600 mcm
3000 / 3200A	92" (2337)	92" (2337)	72" (1829)	72" (1829)	66" (1829)	66" (1829)	3600 lbs (1633)	4250 lbs (1928)	9	#2 - 600 mcm
4000A	92" (2337)	92" (2337)	96" (2438)	96" (2438)	90" (2286)	90" (2286)	6500 lbs (2948)	7500 lbs (3402)	12	#2 - 600 mcm

1 Enclosure dimensions are for reference. (Not intended for construction purposes).

2 All cable connections suitable for copper or aluminum.

3 Enclosure depth shown has cable entry/exit location restrictions. Contact Factory for further detailed information.

* Enclosures painted ASA #61 Gray.

STANDARD FEATURES

- 2.3" back-lit LCD display for monitoring 3 Phase Utility/Generator voltage, system frequency, operation status and alarms
- Five key menu navigation
- Front panel editing with PIN protection
- Customizable status screens
- Load on Utility & Load on Generator indication
- Utility & Generator Source available indication
- 3 Phase Voltage sensing on Utility & Generator Sources
- Generator AC frequency sensing
- Utility under voltage control setpoint 70 - 95% (adjustable)
- Generator under voltage control setpoint 70 - 95% (adjustable)
- Generator under frequency control setpoint 70 - 90% (adjustable)
- Engine warmup timer 0-60 min. (adjustable)
- Utility return timer 0-60 min. (adjustable)
- Engine start timer 0-60 sec. (adjustable)
- Engine cooldown timer 0-60 min. (adjustable)
- Neutral position delay timer 0-120 sec. (adjustable)
- Load Disconnect Contact (LDC) for pre/post transfer control to signal external building systems such as elevators during transfer operations
- Multiple date and time scheduler for On-load or Off-load Programmability
- Real-time clock provides accurate event logging
- Data logging including total transfers to generator, total utility power failures, load on utility hours, load on generator hours and utility or generator voltage/frequency data at time of fault
- Two user Programmable Output Contacts rated 2A, 24VDC resistive and Two user Programmable Output Contacts rated 15A, 24VDC resistive, Form A. Each output contact is user programmable to 20 different functions including: Load on Utility, Load on Gen, Load Disconnect Contact (LDC), Fail to Transfer (FTT), Utility Power Available (UPA), Generator Power Available (GPA), Utility Power Fail, ATS Not in Auto, and ATS in Auto.
- The Transfer Switch is pre-programmed with the following outputs enabled:
 - Load on Utility
 - Load on Gen
 - Load Disconnect Contact (LDC)
 - Fail to Transfer (FTT)
 - ATS Not in Auto



- Local and Remote utility power fail simulation test
- Local plant exercise initiate pushbutton control
- Engine start contact (8A, 120/240VAC resistive max.)
- Transfer fail/forced transfer logic
- Automatic force transfer to alternate supply should load voltage become de-energized
- 24Vdc control power
- Remote Load Test/Peak Shave Input
- NEMA 1 Enclosure
- Solid Neutral on 4 Wire Systems
- Auto Configuring System Voltage Type (3 wire delta or 4 wire Wye capable without additional sensing transformers)
- ATS Generator Bus Power Metering Capability (Amp, Volt, Freq, kW, kVA, PF)*
- Under/Over Frequency Protection - Utility and Generator Sources
- 3 Phase Over Voltage Protection - Utility and Generator Sources
- Phase Sequence and Phase Rotation Protection between Utility and Generator Sources
- Voltage Phase Loss/Unbalance Protection
- Programmable Inputs (Quantity 8 Digital Input-voltage free input)
- RS485 Modbus Remote Communication Port (Modbus™ Serial RTU)
- Optional Ethernet Modbus Remote Communication Port (Modbus™ TCP)
- Optional Remote Annunciator
- Support up to Three Remote Display Unit
- Serviceable Plug-in Connectors

**Power Metering requires Current Transformer Option Kit*



TS 880 ORDERING INFORMATION

When placing an order, specify the following 21 digit ATS MODEL CODE as per the features and applications described below.

1 2 3 4 5 6 7 8 9 10 11 12 13 14 15 16 17 18 19 20 21

T	S	8	8																	
---	---	---	---	--	--	--	--	--	--	--	--	--	--	--	--	--	--	--	--	--

1-3. SERIES

TS - TRANSFER SWITCH

4 & 5. MODEL

88 - 880 SWITCH

6. POLES

3 - 3 - POLES
4 - 4 - POLES

7. CONFIGURATION TYPE

A - ATS
B - BYPASS/ISOLATION ATS
X - SPECIAL

8 - 11. AMPERAGE

800
1000
1200
1600
2000
2500
3000
3200
4000

12. APPLICATION

A - STANDARD
B - SERVICE ENTRANCE
C - DUAL UTILITY CONTROL
D - DUAL STANDBY GEN (Slave ATS)
E - 30 CYCLE STANDARD
F - 30 CYCLE SERVICE ENTRANCE
G - 30 CYCLE DUAL UTILITY (DU)
H - DUAL PRIME GEN CONTROL
I - 30 CYCLE DUAL STANDBY GEN (DSG)
J - 30 CYCLE DUAL PRIME GEN (DPG)
X - SPECIAL

13. OPERATION TYPE

1 - OPEN TRANSITION
2 - MANUAL ELEC. OP.
3 - CLOSED TRANSITION (MOMENTARY)
4 - CLOSED TRANSITION (SOFT LOAD)
X - SPECIAL

14. SAFETY STANDARD

A - UL 1008 (Service Entrance)
C - UL 1008 / CSA 178
X - NOT APPLICABLE

15. VOLTAGE

3Ø 4 WIRE (GROUNDED NEUTRAL)

E - 120/208¹
F - 127/220
G - 120/240¹ (DELTA)
H - 220/380²
S - 230/400²
J - 240/416
K - 254/440
M - 277/480¹
N - 347/600¹

3Ø 3 WIRE

P - 208
Q - 220
R - 240
U - 416
V - 480
W - 600
X - SPECIAL

16. CONTROLLER

5 - TSC 900 c/w GHC GRAPHIC DISPLAY
6 - TSC 7320 c/w LCD DISPLAY
7 - NONE (MANUAL)

17. ENCLOSURE TYPE

A - NEMA1, ASA #61 GRAY
B - NEMA2, ASA #61 GRAY
C - NEMA12, ASA #61 GRAY
D - NEMA3R SD, ASA #61 GRAY
E - NEMA3R DD, ASA #61 GRAY
F - NEMA3RX / 4X DD
(304 STAINLESS STEEL)
G - NONE (OPEN STYLE)
H - NEMA 4X SD
(304 STAINLESS STEEL)
K - NEMA 4X SD
(316 STAINLESS STEEL)
L - NEMA3RX / 4X DD
(316 STAINLESS STEEL)
X - SPECIAL

18. UTILITY SWITCHING DEVICE

Q - INSULATED CASE, FIX MOUNT SWITCH
R - INSULATED CASE, FIX-MOUNT SWITCH
C/W ELECTRONIC TRIP
T - INSULATED CASE, FIX-MOUNT SWITCH
C/W ELECTRONIC & GF TRIP
U - INSULATED CASE DRAW-OUT SWITCH
V - INSULATED CASE DRAW-OUT SWITCH
C/W ELECTRONIC TRIP
W - INSULATED CASE, DRAW-OUT SWITCH
C/W ELECTRONIC & GF TRIP
X - SPECIAL

19. GENERATOR SWITCHING DEVICE

Q - INSULATED CASE, FIX MOUNT SWITCH
R - INSULATED CASE, FIX-MOUNT SWITCH
C/W ELECTRONIC TRIP
T - INSULATED CASE, FIX-MOUNT SWITCH
C/W ELECTRONIC & GF TRIP
U - INSULATED CASE DRAW-OUT SWITCH
V - INSULATED CASE DRAW-OUT SWITCH
C/W ELECTRONIC TRIP
W - INSULATED CASE, DRAW-OUT SWITCH
C/W ELECTRONIC & GF TRIP
X - SPECIAL

20. POWER CONNECTIONS

A - STANDARD
C - ATS CONNECTION PLATE 800A
D - ATS CONNECTION PLATE 1000/1200A
F - ATS CONNECTION PLATE 800A - U & G
G - ATS CONNECTION PLATE 1000/1200A - U & G
H - ATS CONNECTION PLATE 1600A
I - ATS CONNECTION PLATE 2000A
J - ATS CONNECTION PLATE 2500A
K - ATS CONNECTION PLATE 3000/3200A
L - ATS CONNECTION PLATE 4000A
X - SPECIAL

21. ATS CONNECTION CONFIGURATION⁶

A - STANDARD
E - ALTERNATE E
F - ALTERNATE F
G - ALTERNATE G
X - SPECIAL

NOTES:

¹ MULTI-VOLTAGE CAPABLE

² FOR 50 Hz APPLICATION

⁶ FOR BYPASS SWITCH APPLICATIONS
REFER TO FACTORY

OPTIONAL FEATURES (Specify separately from ATS MODEL CODE when ordering)

CODE	DESCRIPTION
AUXILIARIES:	
AUX-BG	Generator Bypass Auxiliary Contact
AUX-BU	Utility Bypass Auxiliary Contact
KOTS-DSE	Key Operated Test Switch - Auto/Off/Engine Start/Test – includes the DSE2130 module
RO2157	Programmable Relay Output Expansion Module - Includes QTY 8, 2A Resistive 30VDC rated relays - 4 NO and 4 Form C Contacts.
TS-STG	24Vdc or 120VAC Shunt Trip Generator Switch (external power source required)
TS-STU	24Vdc or 120VAC Shunt Trip Utility Switch (external power source required)
COMMUNICATION:	
EMB-TCP/IP	Ethernet Modbus™ Remote Communication (Modbus™ TCP) via (DSE855)
RA 7320 (DSE2548)	Remote Annunciator with eight configurable LEDs. Works up to 0.6 miles from the TSC7320. Up to 10 modules can be daisy-chain (Refer to the DSE2548 Datasheet)
RD 7320 (DSE2520)	Remote Display. Up to three display modules can be connected to TSC7320 (Refer to the DSE2510-20 Datasheet)
ENCLOSURE:	
LCK	Enclosure Lockable Door (Single point T-Handle lock)
TS-H1	Enclosure Strip Heater c/w Thermostat (120VAC external power source required)
TS-H2	Enclosure Strip Heater c/w Thermostat (internally powered from ATS load)
FUNCTION:	
MTS	Manually Initiated Electrically Operated Transfer Switch c/w Source Selector Switch, Position Indicating Lights, Source Available Lights
TCP	Transfer Switch Connection Plate for Generator Supply
TS-SS	Internal Multi - Voltage Selector Switch (208V/240V/480V)
METERING:	
LPM-DSE	Transfer Switch Load Power Metering CT Kit (Amp, Volt, Freq, kW, kVA, PF) **Requires CT Kit
CTKxxxx	Current Transformer Kit (xxxx -Specify CT Size 800, 1200, 1600, 2000, 3000, 4000). **Requires GPM Option
MUP	Multifunction Utility Protective Relay – Basler™ IPS100 (Protection Functions 27, 32, 47, 50/51, 67, 81O/U) NOTE: May be required by local utility for Momentary CT applications. Consult factory for other makes and models.
POWER:	
SPD	Surge Protection Device
OTHER:	
3YR	Additional 12 Month Parts & Labour Warranty
5YR	Additional 48 Month Parts & Labour Warranty



NOTES:





Thomson Power Systems
4916 - 275th Street
Langley, BC, Canada V4W 0A3
Customer Service: 604-888-0110
info@thomsonps.com
www.thomsonps.com



NOTE: Specifications subject to change without notice.

APPLICATION CONSIDERATIONS

The proper selection and application of power generation products and components, including the related area of product safety, is the responsibility of the customer. Operating and performance requirements and potential associated issues will vary appreciably depending upon the use and application of such products and components. The scope of the technical and application information included in this publication is necessarily limited. Unusual operating environments and conditions, and other factors can materially affect the application and operating results of the products and components and the customer should carefully review its requirements. Any technical advice or review furnished by Regal Beloit America, Inc. and its affiliates with respect to the use of products and components is given in good faith and without charge, and Regal assumes no obligation or liability for the advice given, or results obtained, all such advice and review being given and accepted at customer's risk.

For a copy of our Standard Terms and Conditions of Sale, Disclaimers of Warranty, Limitation of Liability and Remedy, please contact Customer Service at 1-888-888-0110. These terms and conditions of sale, disclaimers and limitations of liability apply to any person who may buy, acquire or use a Regal Beloit America Inc. product referred to herein, including any person who buys from a licensed distributor of these branded products.

Thomson Power Systems and Regal are trademarks of Regal Beloit Corporation or one of its affiliated companies.

©2016, 2017 Regal Beloit Corporation, All Rights Reserved. CL061 Rev 15 19/09/17

