



Technical Data Sheet

STANDARD CONFIGURATION - USA

TDS2818 – *mtu* Kinetic PowerPack Single

Voltage/Frequency	480V / 60Hz
Rated Power	400 kW (500 kVA at p.f. 0.8)
Critical Power	400 kW (500 kVA)
Diesel Engine	MTU 10V1600G80S EO EPA
Revision	02

Table of contents

1	SYSTEM GENERAL SPECIFICATIONS.....	4
1.1	Ratings	4
1.2	Key dimensions and weight of the mtu Kinetic PowerPack	4
1.3	Air flow requirements	4
1.4	Noise levels in conditioning mode (measured at 1 meter)	5
1.5	Engine noise levels (measured at 1 meter)	5
1.6	Exhaust noise levels (measured at 1 meter).....	5
1.7	Noise levels in independent mode (measured at 1 meter).....	5
1.8	Vibrations.....	5
1.9	Power module colours.....	5
1.10	Special features.....	5
2	DIESEL ENGINE.....	6
2.1	Main features	6
2.2	Special features and auxiliaries.....	6
2.3	Fluids capacities	7
2.4	Fuel.....	7
2.5	Exhaust.....	7
2.6	Radiator	8
2.7	Electric starting system.....	8
3	ELECTROMAGNETIC CLUTCH	9
4	STATO-ALTERNATOR	10
5	POWER PANEL.....	11
6	CHOKE	11
6.1	Dimensions and weight	11
7	AUXILIARY PANEL (One per unit).....	12
7.1	Dimensions and weight	12
8	CONTROL PANEL.....	13
8.1	Dimensions and weight	13
8.2	HMI touch screen.....	14
8.3	Built in features.....	15
8.4	Communication bus length.....	15
9	SINGLE LINE DIAGRAM.....	16
10	ELECTRICAL PERFORMANCES.....	17
10.1	Acceptable mains tolerance in conditioning mode	17
10.2	Voltage regulation (conditioning and independent mode)	17
10.3	Frequency regulation in independent mode	17
10.4	Harmonics	17

NOTES:

- Information is given for guidance only and is subject to adjustment at the final design stage.
- Pictures are not contractual.

1 SYSTEM GENERAL SPECIFICATIONS

1.1 Ratings

Characteristics	Value	Unit	Remark
Rated critical power	400 (500)	kW (kVA)	at p.f. = 0.8
Overload in conditioning and independent modes	10	%	of rated critical power
Maximum load step	100	%	of rated critical
Efficiency	93	%	In conditioning mode, including

1.2 Key dimensions and weight of the mtu Kinetic PowerPack

See drawing 370315.

Normal service conditions

Min./Max. temperature	Min./Max. relative humidity	Maximum altitude	Air quality
-25°C / 40°C (-13°F/104°F)	20 / 90 % non condensing	400 m a.s.l. (1312 ft)	No dust or sand loaded air

Except if otherwise stated, all values of this data sheet are given for above environmental conditions. For conditions out of these limits, please consult with us: air-conditioned power and control panels are available, filters can be added for application in dusty/sandy environments... For more details on air quality, refer to document TI0047 - Environmental conditions. For storage/transport conditions please consult with us.

1.3 Air flow requirements

Working mode	Air purpose	Value	Unit
Conditioning mode	Ventilation	10800(6357)	m ³ /h (cfm)
Independent mode	Combustion	2100(1236)	m ³ /h (cfm)
Option 1: Skid mounted radiator with mechanically driven fan			
	Cooling	38520(22672)	m ³ /h (cfm)
	TOTAL	40620 (23908)	m ³ /h (cfm)
Option 2: NA			
	Cooling	NA()	m ³ /h (cfm)
	TOTAL	NA	m ³ /h (cfm)

1.4 Noise levels in conditioning mode (measured at 1 meter)

Freq. (Hz)	63	125	250	500	1000	2000	4000	8000	Global
Pressure	93dB	92dB	96dB	96dB	95dB	91dB	87dB	82dB	99dB(A)

1.5 Engine noise levels (measured at 1 meter)

Freq. (Hz)	63	125	250	500	1000	2000	4000	8000	Global
Pressure	90dB	100dB	94dB	91dB	89dB	98dB	91dB	92dB	101dB(A)

1.6 Exhaust noise levels (measured at 1 meter)

Freq. (Hz)	63	125	250	500	1000	2000	4000	8000	Global
Pressure	104dB	112dB	105dB	104dB	102dB	89dB	73dB	58dB	106dB(A)

1.7 Noise levels in independent mode (measured at 1 meter)

Freq. (Hz)	63	125	250	500	1000	2000	4000	8000	Global
Pressure	95dB	100dB	98dB	97dB	96dB	99dB	93dB	92dB	103dB(A)

1.8 Vibrations

More than 96% of the vibrations are eliminated by vibrations dampers inserted between an intermediate frame and the main frame, thus allowing the power module to be laid directly on the ground.

1.9 Power module colours

Engine	Stato-Alternator	Frame
RAL 7001 (Silver grey)	RAL 9010 (Pure white)	RAL 5002 (Ultramarine blue)

1.10 Special features

Accessories	Included
Vibration monitoring - Stato-Alternator	No
Bearings automatic greasing (AGB)	No
Electrical measurements real-time recording	No
Engine automatic lubricant refill	No

2 DIESEL ENGINE

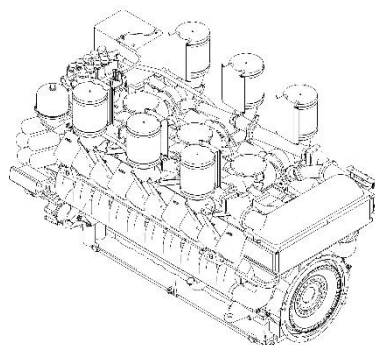

2.1 Main features

Characteristic	Value	Unit	Remark
Brand	MTU		
Model	10V1600G80S EO EPA		
Rated speed	1800	RPM	
Displacement	17.5	l	
Number of cylinders	10		
Electrical system	24	V DC	
Prime power (PRP)	511(685)	kW (BHP)	At 25°C and 100kPa according to ISO
Standby power (ESP)	561(752)	kW (BHP)	3046

2.2 Special features and auxiliaries

Accessories	Included
Prelubrication pump	Yes
Manual oil sump extraction pump	Yes
Water circuit preheating with thermostatic control and circulation pump	Yes
Air/water charge air cooler	No
Oil pressure electrical sensor	Yes
Water temperature electrical sensor	Yes
Overspeed electrical sensor	Yes
Fuel cooler	Yes

2.3 Fluids capacities

Fluid type	Quantity	Unit
Lubricating oil capacity (total)	60.5(16)	l (US gal)
Lubricating oil consumption at rated power	NA(NA)	l/h (US gal/h)
Coolant capacity in engine circuit (radiator not included)	60(16)	l (US gal)
Coolant capacity in aftercooler circuit (if applicable and radiator not included)	-(-)	l (US gal)

2.4 Fuel

Fuel consumption (Admissible tolerance: +/-5%) at 100% ESP	g/kWh	l/h (US gal/h)
at 100% ESP	190	125(33)
at 25% rated output power	247	34(9)
at 50% rated output power	228	62(16)
at 75% rated output power	207	84(22)
at rated output power	193	105(28)

Other characteristics	Value	Unit
Fuel maximum inlet temperature	60(140)	°C (°F)
Maximum fuel flow	402(106)	l/h (US gal/h)

2.5 Exhaust

Characteristics	Value	Unit
Exhaust gas flow	5800(3414)	m ³ /h (cfm)
Exhaust gas temperature	459(858)	°C (°F)
Heat rejection to exhaust	NA(NA)	kW (BTU/min)
Exhaust back pressure (Design value)	85(1.23)	Mbar (psi)
Maximum exhaust back pressure	150(2.18)	Mbar (psi)

Exhaust emissions (ESP)	Value	Unit
Complies with	EPA T2	
NO _x	6.4	g/kWh
CO	3.5	g/kWh
Particulate matter (Dust)	0.2	g/kWh

2.6 Radiator

Characteristics	Value	Unit
Maximum air temperature at radiator outlet	< 85(185)	°C (°F)
Maximum total power consumption of the fans (*)	20	kW
Heat rejection, engine cooling circuit	265(15070)	kW (BTU/min)
Heat rejection, aftercooler circuit	105(5971)	kW (BTU/min)
Max. static head of coolant above engine	15(49)	m (ft)
Engine circuit		
Max. pressure drop external to engine	70(10)	kPa (psi)
Coolant flow rate	28(7397)	m³/h (US gal/h)
Coolant temperature FROM engine	95(203)	°C (°F)
Aftercooler circuit		
Max. pressure drop external to engine	0()	kPa (psi)
Coolant flow rate	0(0)	m³/h (US gal/h)
Coolant temperature TO aftercooler	-(-)	°C (°F)
Option 1: Skid mounted radiator with mechanically driven fan		
Static pressure reserve	200 (0.03)	Pa (psi)
Radiator air inlet temperature	45(113)	°C (°F)
Option 2: NA		
Static pressure reserve	NA	Pa (psi)
Radiator air inlet temperature	NA	°C (°F)

(*) If a remote radiator is used, this value includes the power of both the radiator fans and the power module cooling fans in independent mode. Please consult with us for proper selection and dimensioning of remote radiator.

2.7 Electric starting system

Qty of starters	System voltage	Type of batteries	Total Cold Crank Amps @ 24VDC	
			CCA DIN -0°F	CCA EN -0°F
2	24 V	Maintenance free, lead acid	1600A	2560 A

NOTES:

- 12VDC batteries are connected in series by pairs to obtain 24VDC.
- The required number of pairs of batteries is derived out of the Total CCA divided by the respective CCA (DIN or EN) of one battery, rounded up to a multiple of the quantity of starters.

3 ELECTROMAGNETIC CLUTCH

Characteristics	Value	Unit
Brand	Stromag	
Model	MEA-A 400	
Features	Brushless, ringless, lubrication and maintenance free	
Excitation	24	V DC
Coupling	Rubber type	
Housing	PI-400/400/1/14	

4 STATO-ALTERNATOR

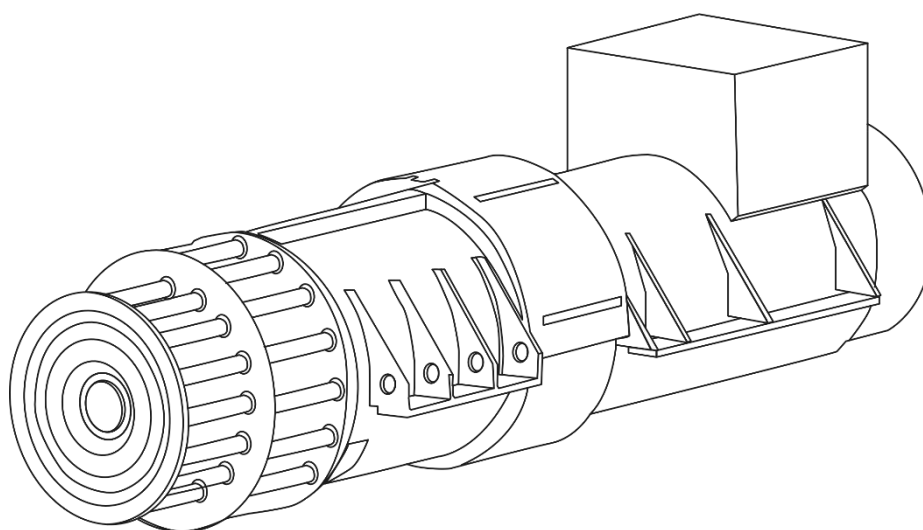

Characteristic	Value	Unit	Remark
Brand	RRSL		
Model	KS5-400D-1J-A4		
In accordance with	IEC standards		
Rotating speed (inner/outer rotor)	1800/3600	RPM	
Rated frequency	60	Hz	
Voltage	480	V AC	
Power factor	0.8		Lagging
Rated current (In)	601	A	
Continuous output power	500	kVA	
Max. capacitive reactive power	70	kVAr	
Insulation temperature class	Class H		
Operation to class	Class F		
Protection degree	IP23		
Short circuit current to upstream	3	In	From KP only
Short circuit current to downstream	23	In	From KP only

5 POWER PANEL

See specific document.

6 CHOKE

Characteristics	Value	Unit
Inductance Type	3 single-phase	
Assigned Power	500	kVA
In accordance with	IEC standard	
Rated frequency	60	Hz
Voltage	480	V AC
Protection degree	IP 23	
Standard colour	RAL 7035 (Light grey)	

6.1 Dimensions and weight

Characteristics	Value	Unit
Width	2544 (100)	mm (in)
Depth	816 (32)	mm (in)
Overall height	2350 (93)	mm (in)
Weight	2600 (5732)	kg (lb)

NOTES:

- Dimensions and weight are estimates and must be confirmed after detailed design phase.

7 AUXILIARY PANEL (One per unit)

The AXL panel is intended to distribute AC voltages to the auxiliaries (radiator, fuel pump, etc). The continuous availability of these voltages is critical for the good operation of the **mtu** Kinetic PowerPack installation, which is why it is supplied from the downstream bus of the Power Panel.

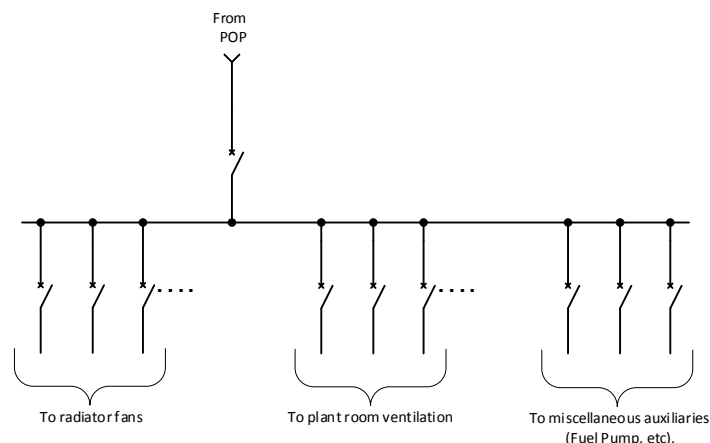

Characteristics	Value	Unit
Min operating ambient temperature	5 (41)	°C (°F)
Max operating ambient temperature (*)	40 (104)	°C (°F)
Complies with	UL 508A	
Protection degree	IP43	
Standard colour	RAL 7035 (Light grey)	

(*) Average over 24h not to exceed 35°C

7.1 Dimensions and weight

Characteristics	Value	Unit
Width	1000 (39)	mm (in)
Depth	500 (20)	mm (in)
Overall height	2210 (87)	mm (in)
Weight	400 (882)	kg (lb)

NOTES:

- Dimensions and weight are estimates and must be confirmed after detailed design phase.
- Provide approximately 10 cm above panel top to allow ventilation air to escape freely.
- Cable entry possible from top.

8 CONTROL PANEL

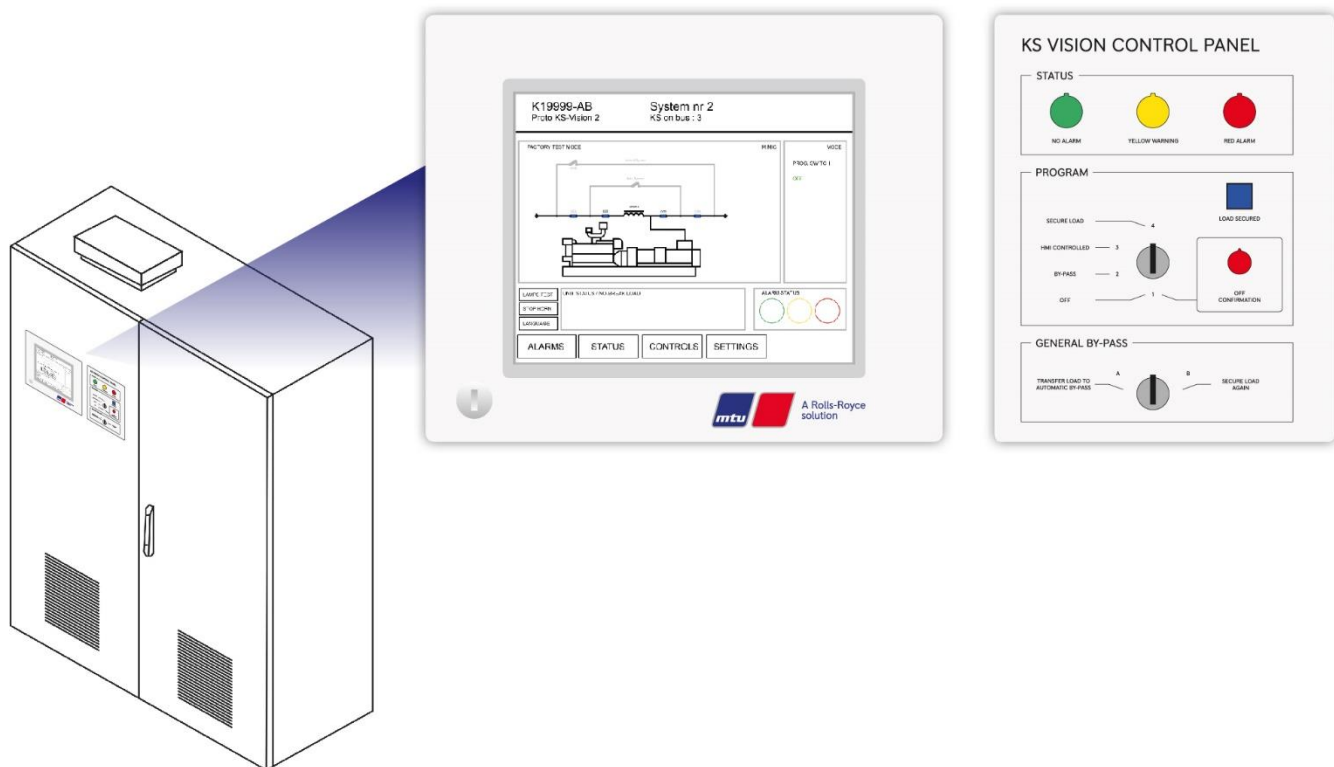

Characteristics	Value	Unit
Min operating ambient temperature	5 (41)	°C (°F)
Max operating ambient temperature (*)	40	°C
Complies with	UL 508A	
Protection degree	IP43	
Standard colour	RAL 7035 (Light grey)	

8.1 Dimensions and weight

Characteristics	Value	Unit
Width	1600(63)	mm (in)
Depth	500(20)	mm (in)
Overall height	2210(87)	mm (in)
Weight	560(1235)	kg (lb)

NOTES:

- Dimensions and weight are estimates and must be confirmed after detailed design phase.
- Provide approximately 10 cm above panel top to allow ventilation air to escape freely.
- Cable entry possible from top, bottom, left or right. To be specified when ordering.

Rolls-Royce Group
www.mtu-solutions.com

13/17

This document is the property of Rolls-Royce Solutions Liège S.A. and may neither be disclosed nor reproduced without written authorization. Information provided is believed to be correct and reliable. Rolls-Royce Solutions Liège S.A. reserves the right to amend this document without notice.

8.2 HMI touch screen

The HMI touch screen located on the front door provides access to:

- Measurements (voltage, frequency, power factor, temperature...)
- Controls (secure load, by-pass, engine test, mains fault test...)
- Status (alarms, maintenance, position of breakers...)
- Language selection (integrated languages: EN, FR, DE, ES, NL...)
- Settings (clock, scheduling of maintenance and system tests...)

The following screens give some examples of these functionalities.

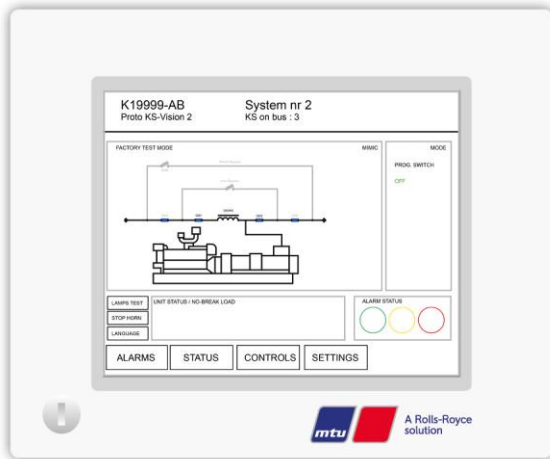

HMI Main Screen

General information and access to other screens.

HMI Electrical Measurements

Displays all needed electrical measurements like voltage, current, power factor...

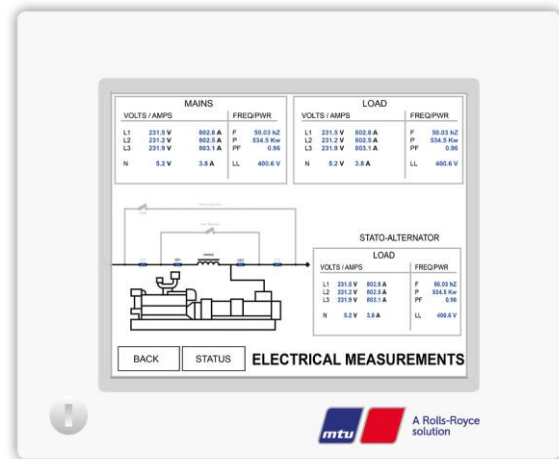

HMI KP Measurements

Displays mechanical information like fuel tank level or bearings temperatures.

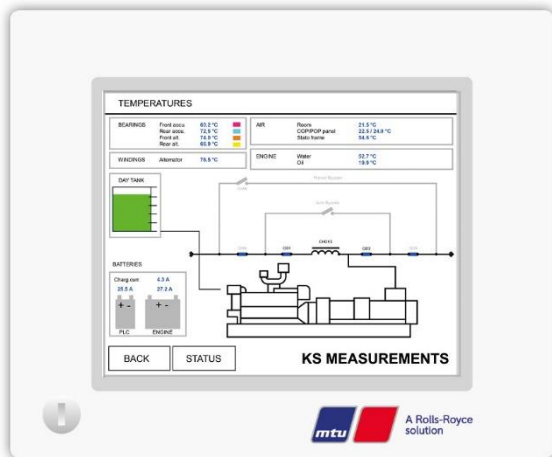

8.3 Built in features

The following features/components are part of the KS-VISION® system and are integrated in the Control Panel:

- Digital Control Module (DCM) is responsible for the real-time control which includes:
 - Accu inner and outer rotor speed regulation
 - Voltage regulation
 - Mains failure detection
 - Synchronizer control
 - ...
- SAIA Programmable Logic Controller (PLC)
- Communication means:
 - Remote supervision over Ethernet (Modbus TCP/IP available as an option)
 - Digital I/O's
- Accu maintenance braking
- Energy storage and recovery checks
- Engine speed control and regulation
- Emergency stop
- ...

8.4 Communication bus length

Two communication protocols are used: Profinet (PLC) and Canbus (DCM and rEDBus). The communication buses must have the following characteristics:

- Ethernet:
 1. Cat6 or better
 2. Individual and overall shield (S/FTP or equivalent)
 3. Maximum cable length (point to point): 100m
- Canbus:
 1. Canbus certified cable
 2. Maximum bus length: 400m
 3. Characteristic impedance: 120 Ω at 1MHz
 4. Section: 0.75 mm² (18 AWG)

With bus length being defined as the length of cable between the first and last equipment communicating.

9 SINGLE LINE DIAGRAM

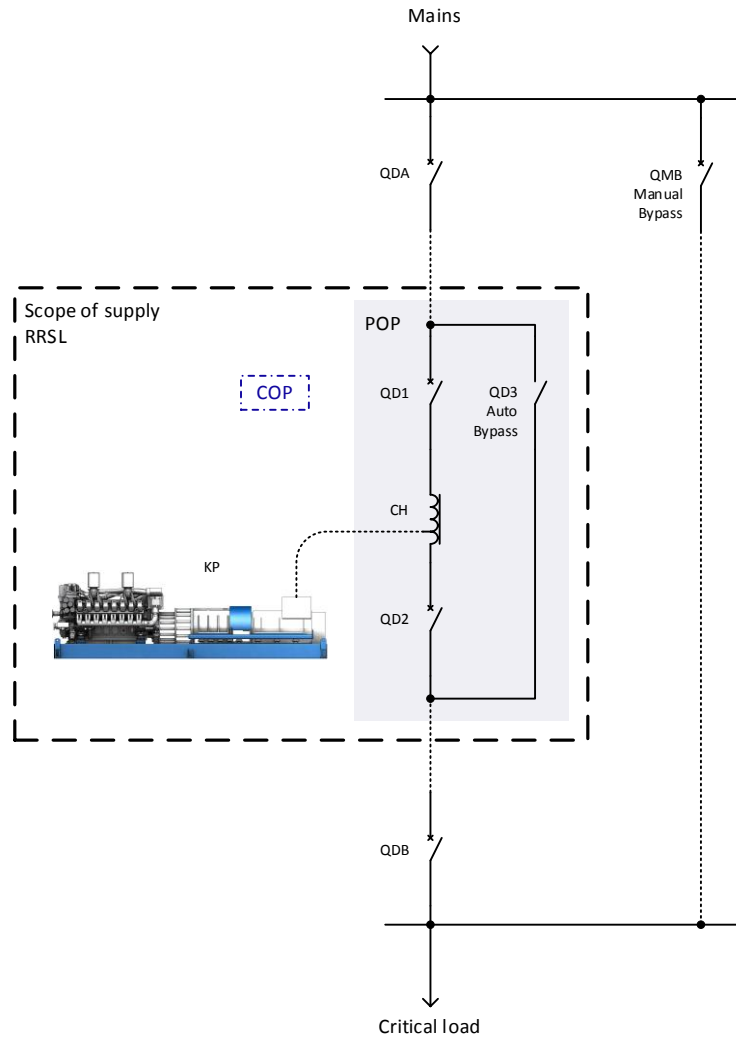

10 ELECTRICAL PERFORMANCES

10.1 Acceptable mains tolerance in conditioning mode

Characteristics	Value
Frequency tolerance (Permanent)	± 0.4 Hz
Voltage tolerance (Permanent)	± 10 %

10.2 Voltage regulation (conditioning and independent mode)

Conditions	Value
In steady state conditions	± 1 %
For load variation of 10%	± 1 %
For load variation of 50%	± 5 %
On mains failure at 100% load	± 5 %

10.3 Frequency regulation in independent mode

Conditions	Value
In steady state conditions	± 0.2 %
For load variation of 10%	± 0.5 %
For load variation of 50%	± 1 Hz
On mains failure at 100% load	± 1 Hz

10.4 Harmonics

Characteristics	Value
Total harmonic distortion (THD) on linear load	≤ 3 %

10.5 Phase angle

Conditions	Value
With balanced load	$120^\circ \pm 0^\circ$
With 25 % unbalanced load	$120^\circ \pm 1^\circ$

NOTE:

- Typical values.